



EconoSnap Fascia

Installation Guide for EconoSnap Fascia

4 COMMERCE WAY, ARDEN, NC 28704 USA
800-892-9173 828-676-1700
OMGEDGESYSTEMS.COM



EdgeSystems



Installation Guide for EconoSnap® Fascia



ANSI/SPRI/FM4435/ES-1 TESTED

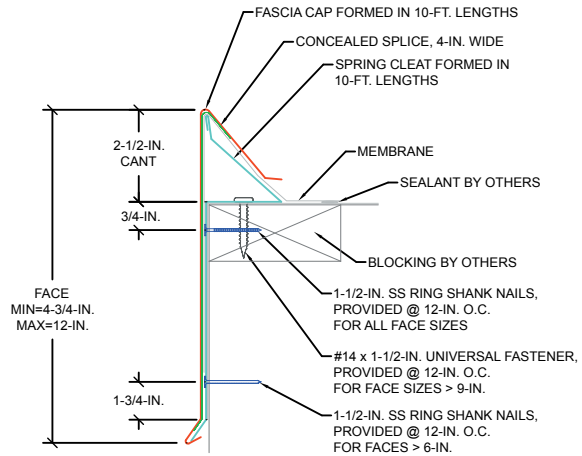

FOR MASONRY APPLICATIONS, PLEASE CONTACT OMG.

CONTACT OMG FOR APPROPRIATE RECOMMENDATIONS NEEDED TO MEET/EXCEED ANSI/SPRI/FM4435/ES-1 DESIGN CRITERIA

NOTES:

- #1 - Isolate all metal parts from ACQ treated wood or other galvanically incompatible material with appropriate membrane material.
- #2 - Appliance attachments, such as lightning rods, signs, or antennae that penetrate the edge system, induce a galvanic reaction, or otherwise compromise the effectiveness of the roof edge system, shall be eliminated or isolated to prevent problems per ANSI/SPRI/FM4435/ES-1. Lightning protection systems for example must not be directly affixed to the product provided by OMG. Consult OMG for alternative attachment suggestions.

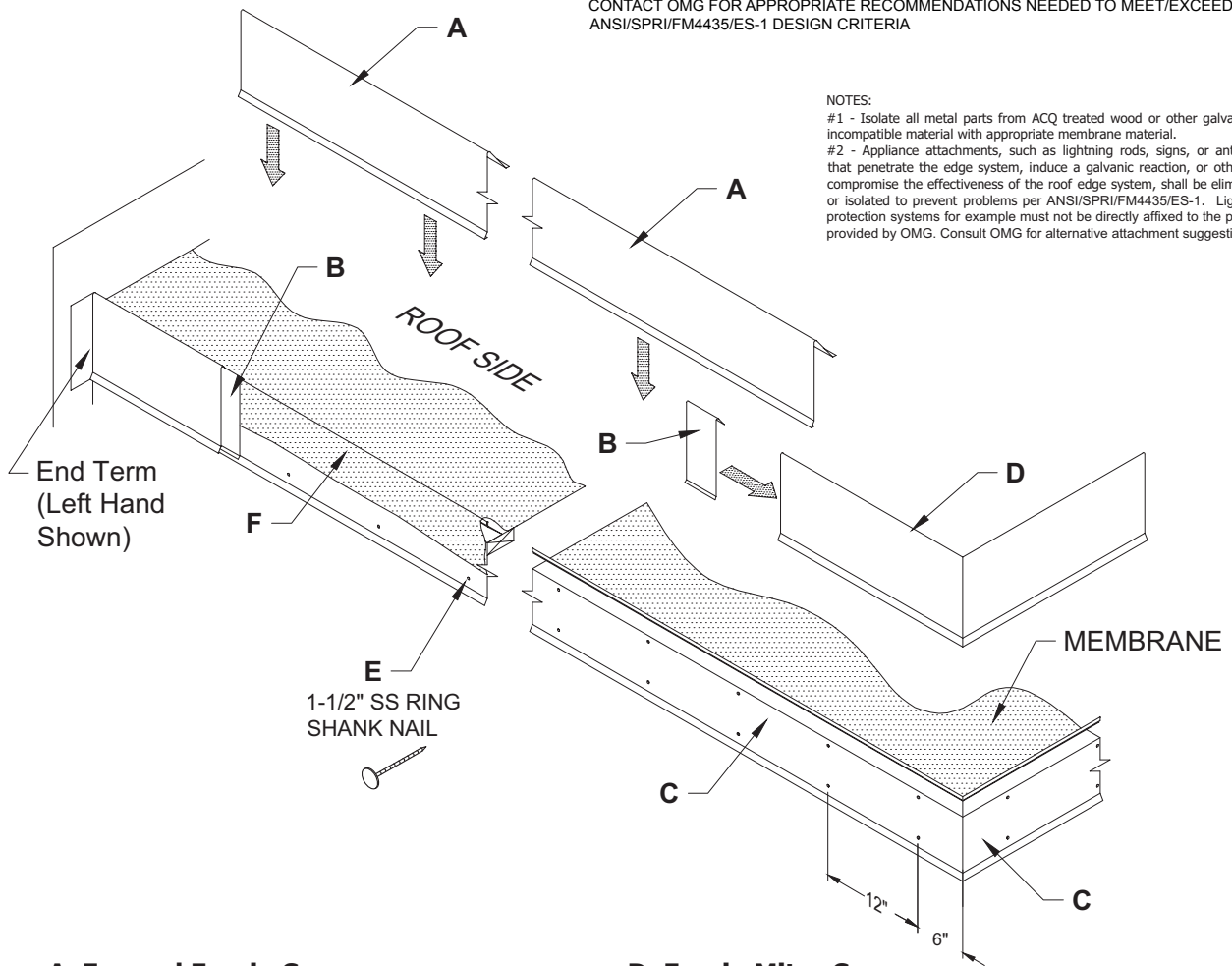

- A. Formed Fascia Cover**
10'-0" Lengths
- B. Concealed Joint Splice**
4" Lengths
- C. Galvanized Steel Spring Cleat**
10'-0" Lengths

- D. Fascia Miter Cover**
(Outside Corner Shown)
- E. 1-1/2" SS Ring Shank Nail**
at 12" o.c. (6" from ends) for cleat
(Included & Required)
- F. Strip-In Ply**
(By Installer)

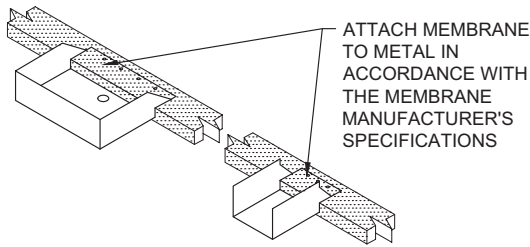

STEP 1: Consider Sump Core & Spillout Locations

Locate sump cores where downspouts will be located. Sump cores are installed prior to the spring cleat. The spring cleat butts up to side(s) of sump core. Spillouts are installed along with the fascia lengths as required. Refer to "Spillout & Sump Core Install Guides" for more info on installation if necessary.

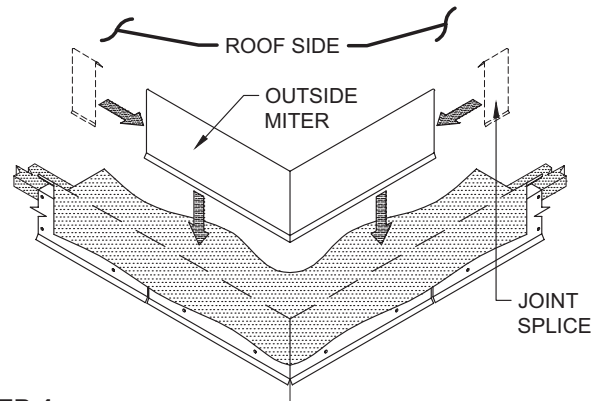

STEP 4: Installing Fascia Miters

Locate the miter and concealed joint splice for the appropriate corner. Place a concealed joint splice in each side of the miter. Center the miter over the spring cleat, then press downward on the top of the miter until the drip of the miter fully engages the kick out of the spring cleat. Miters have 24" nominal leg lengths.

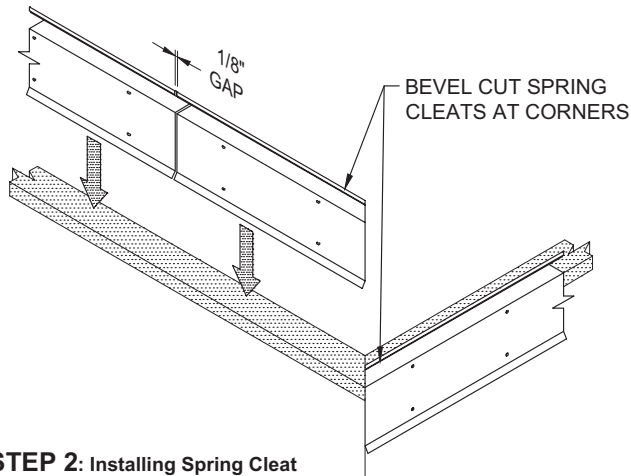

STEP 2: Installing Spring Cleat

Prior to installing the spring cleat, ensure that all metal components have been isolated from ACQ treated lumber with appropriate membrane material. Field cut spring cleat to fit corner conditions. Install spring cleat working away from corners. Allow 1/8" gap between sections for thermal movement. Attach the spring cleat using the 1-1/2" ss ring shank nails provided in each pre-punched hole.

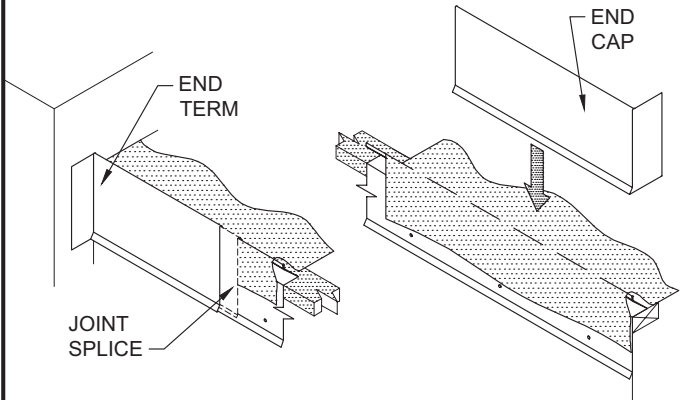

STEP 5: Installing Fascia End Caps and End Terms

Install the fascia end caps and end terms by pressing downward on the top flange until the drip of the fascia has fully engaged the kick out of the spring cleat.

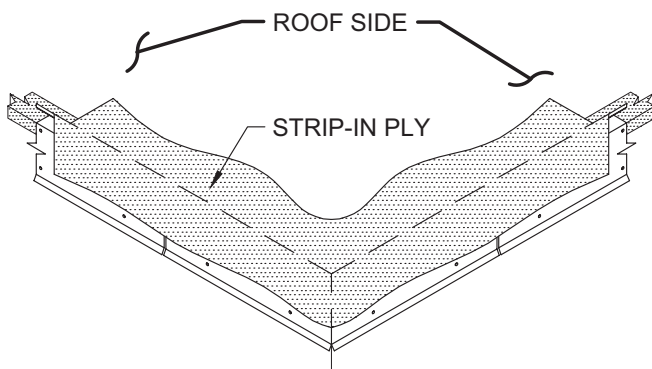

STEP 3: Installing Strip-in Ply

Install the strip-in ply in accordance with the manufacturer's specifications. Strip-in ply should extend down the vertical surface of the spring cleat. DO NOT extend past the kick out.

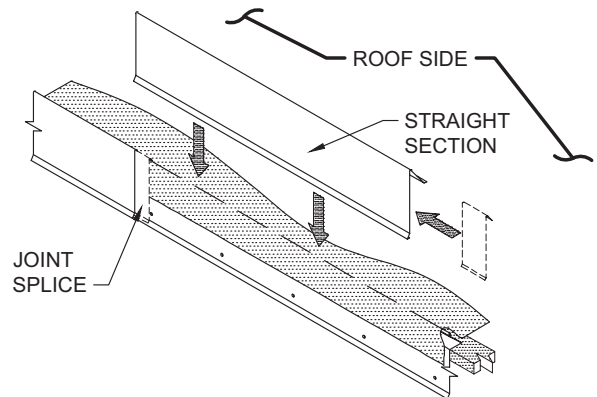

STEP 6: Installing Fascia Straight Lengths

Place a concealed joint splice in the opposite end of the installed miter or end cap. Install the fascia by pressing downward on the top flange until the drip of the fascia has fully engaged the kick out of the spring cleat. **Allow a 1/4" gap between fascia sections for thermal expansion.** Review lengths of all straight pieces prior to cutting to avoid creating relatively short sections of fascia adjacent to full length sections.

Note: There must be a joint splice at every joint.



SUMP CORES

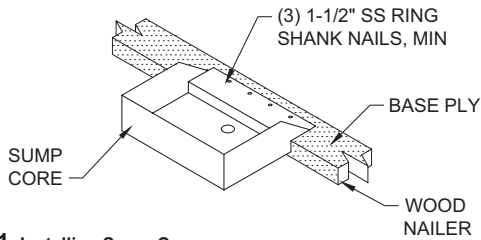

STEP 1: Installing Sump Core

Locate sump cores where downspouts will be located. Sump cores are installed prior to the spring cleat. Fasten sump core to the wood nailer with a min of (3) 1-1/2" ss ring shank nails.

SPILLOUTS

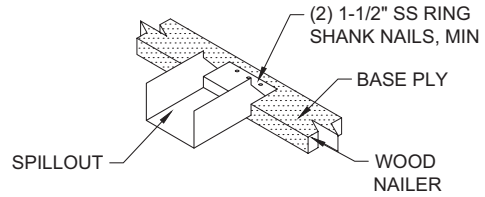

STEP 1: Installing Spillouts

Spillouts are installed at predetermined locations. Spillouts are installed prior to the spring cleat. Fasten spillout to the wood nailer with a min of (2) 1-1/2" ss ring shank nails.

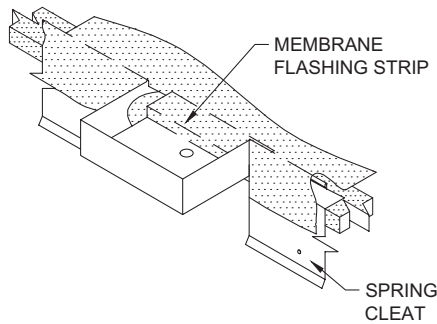

STEP 2: Installing Spring Cleat at Sump Core

Butt spring cleat to the sump core. Apply membrane flashing strip over the spring cleat and into the sump core as required by membrane manufacturer's specifications. Splice and seal the membrane in and around the sump core in accordance with membrane manufacturer's specifications.

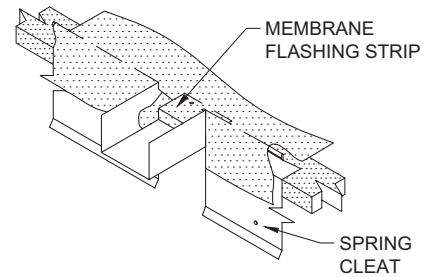

STEP 2: Installing Spring Cleat at Spillouts

Butt spring cleat to the spillout. Apply membrane flashing strip over spring cleat and into the spillout as required by membrane manufacturer's specifications. Splice and seal the membrane in and around the spillout in accordance with membrane manufacturer's specifications. (DON'T LEAVE ANY SHARP EDGES AGAINST THE MEMBRANE.)

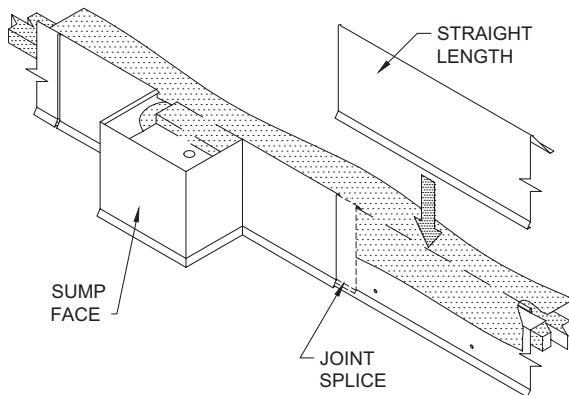

STEP 3: Installing Sump face

Place a concealed joint splice in each end of sump face. Install sump face by hooking the fascia snugly over the top of the spring cleat. Press down on the fascia until the drip edge is engaged.

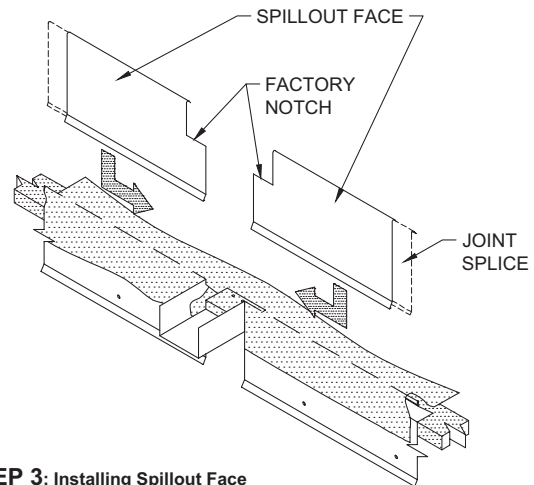

STEP 3: Installing Spillout Face

Place a concealed joint splice in end of fascia. Place fascia snugly over the top of the spring cleat. Press down on the fascia until the drip edge is engaged. Slide fascia into place.

